

ELECTRONIC AND COMPUTER ENGINEERING Brunel Institute of Power Systems (BIPS)

Electronic and Computer Engineering has over last year embarked on a new plan for restructuring its research in line with the main areas of strength identified in the RAE submission and documentations. The main criterion applied for research “clustering” is based on the major areas of strength which the subject area is committed to sustaining and consolidating in the new REF period. These thematic areas form the basis of our teaching and research expertise and justify the investment the university has committed in recent appointments and research infrastructure

Over the last 20 years the BIPS research group has established a track record of international excellence with regard to the research and development of advanced computational tools (both software and hardware) for the analysis, control, operation, management and strategic design of electrical power generation, transmission and distribution systems.

The efficient utilisation of fossil and renewable energy resources with regard to the sustainable generation, transmission and distribution of electrical power has a major impact on the environment.

The following academic staff are included within the BIPS research Group; Professor Malcolm Irving, Dr Gareth Taylor, Dr Mohamed Darwish, Dr Ahmed Zobaa and Dr. Michael Theodoridis. The group also includes a computing officer Dr Jeremy Daniel.

At present the Group also includes post-doctoral academic visitors, 3 research assistants and 20 PhD research students.

Current Activities

The following research and development activities of the Centre cover a wide range of technology areas in the field of electrical power systems that have a major impact on energy resources and the environment:

Power Systems Analysis and Control

Research activity concerns the research and development of extensive computational tools for simulating the dynamic behaviour, control and monitoring of power systems. Such tools can be utilised within an operational

power system control centre and can be configured to reflect either current or future planned operational procedures. Considerable use is made of artificial intelligence techniques for condition monitoring, network planning and optimisation of operational procedures.

Research topics include state estimation, load flow analysis, load-frequency control, economic allocation of generation, unit scheduling and integrating these and other studies within an overall strategy for control and energy management. Aspects of pricing and tariffs are also being investigated. Particular attention has been paid to the man-machine interfacing requirements for operating large modern interconnected power systems. Novel cloud-computing systems are currently under investigation for new and efficient ways of monitoring, processing and displaying dynamic and topological power network data.

Electricity Markets and Power System Economics

Unprecedented global reform and restructuring of the electrical power industry has imposed tremendous challenges on the market operation of existing and future power systems and markets. The group has a record of international excellence in research and development of advanced computational tools for efficiently operating market-oriented power systems. Recent research covers all the major operational issues, such as scheduling and dispatch, congestion management, available transfer capability calculation, price forecasting and optimal bidding strategies. State-of-the-art optimization techniques including genetic algorithms, ant colony search and particle swarm methods have been successfully applied.

Power Electronics and FACTS

The main area of research is the efficient regulation and control of power and energy flow in systems incorporating electrical circuits, machines and systems using power electronics. A major investigation over the past decade has been in the area of active filters for improving power quality and reactive control in electrical power networks. With the tremendous growth in the use of computers on industrial sites and commercial buildings, there is growing concern about their impact on power quality.

A major initiative funded by industry and government agencies is under way to build active filters for controlling current harmonics based on the switched-capacitor technique pioneered at Brunel. The application of this technique to flexible AC transmission systems (FACTS) for reactive power and stability control in power distribution and transmission systems is under investigation.

Other important areas of study include switched-mode and resonant power supplies, and application of DSPs, neural networks and fuzzy logic in power electronics systems.

The research of the BIPS Group has been extensively supported by grants from the EPSRC, EU, DTI, and industry.

The group has collaborated on national and international research projects with institutions and companies such as; Tsing Hua University, China; University of Plzen, Czech Republic; University of Santa Caterina, Brazil; National Grid Company, UK; British Energy, UK; ALSTOM; BNFL, UK, SINTEF Norway.

Facilities

The BIPS research Group in the School of Engineering and Design was established in 1991 and is led by Professor Malcolm Irving and Dr Gareth Taylor. The group received £500K SRIF funding in 2003 to establish a state-of-the-art research laboratory to provide power systems hardware and software support for research. The laboratory also includes a new Grid computing facility.

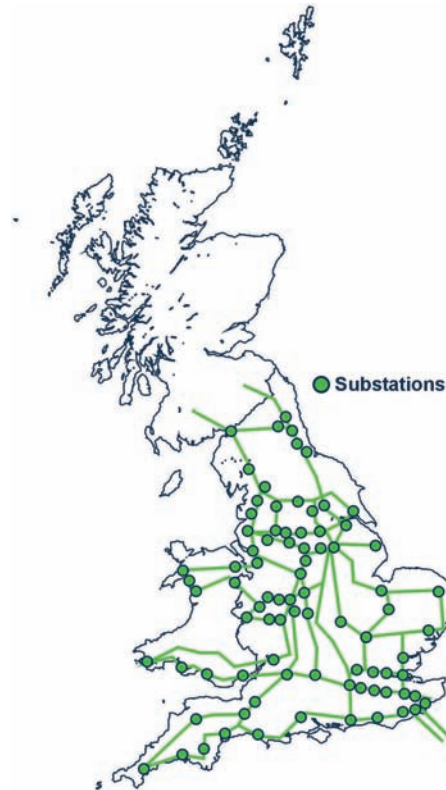

South West Peninsula of the UK 400/275 KV Transmission Network

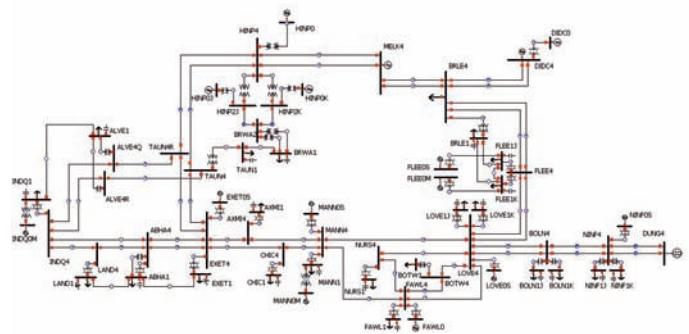

Computational Model of the 400/275 KV Transmission Network for the South West Peninsula, UK (Model was created using the Power World software)