

GEA Searle

Engineering at its best

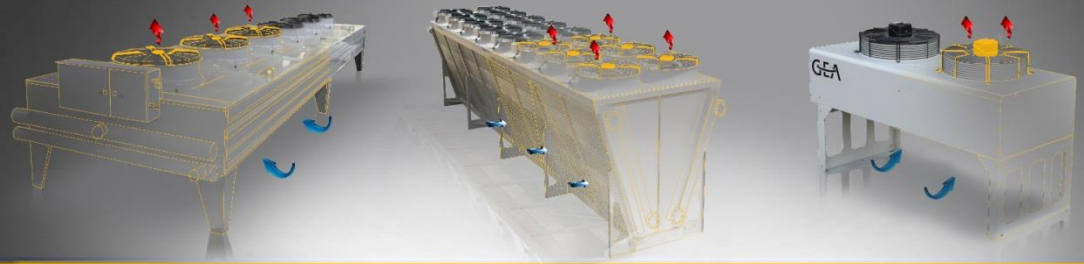

GEA working with CSEF-Case Study

Nick Atkins

Technical Manager

GEA Heat Exchangers

CASE STUDY for CSEF working with GEA

- Introduction to GEA Searle
- Why Work with Academia?
- Why We Chose CSEF-Brunel?
- Gas Cooler Project - Energy Saving
- Heat Exchanger Optimisation
- Carbon Dioxide ORC Project
- Working with Innovate UK
- Project Completion and Beyond



Brunel
University
London

Innovate UK
Technology Strategy Board



RCUK Centre for Sustainable Energy Use in Food Chains



- GEA Searle – 94 years experience in the design and manufacture of heat exchangers
- Many years working closely with the refrigeration industry to align with system innovations
- GEA Searle has embraced the re-emergence of CO₂ as a refrigerant and has worked on many customer collaborations dating back to 1997
- We have recently completed a 2 year research project with Brunel University on CO₂ Gas Coolers



Typical Searle Product

Condensers, Dry Coolers & Gas Coolers



Evaporators & Glycol Coolers



Also, condensing units.

Product Breakdown

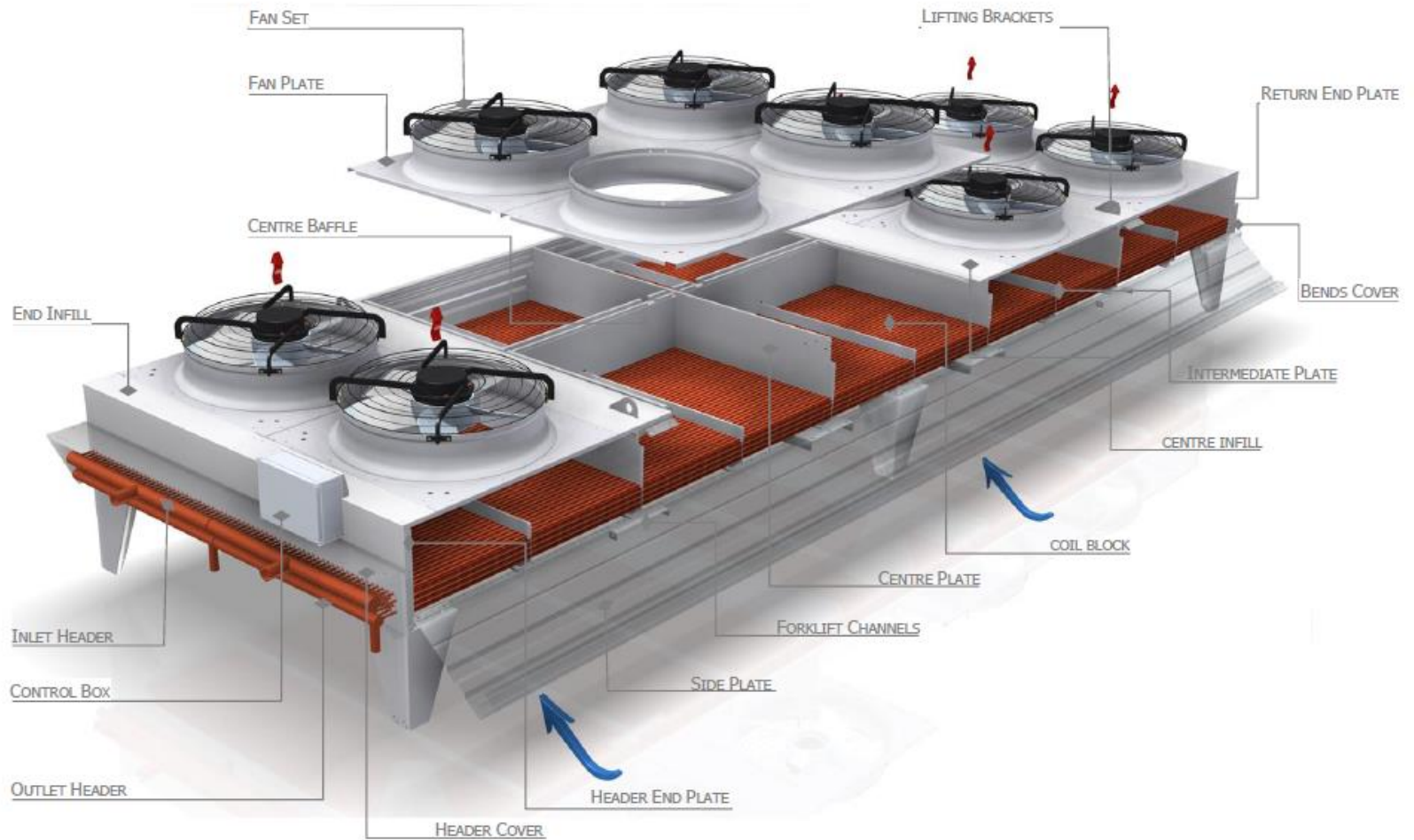

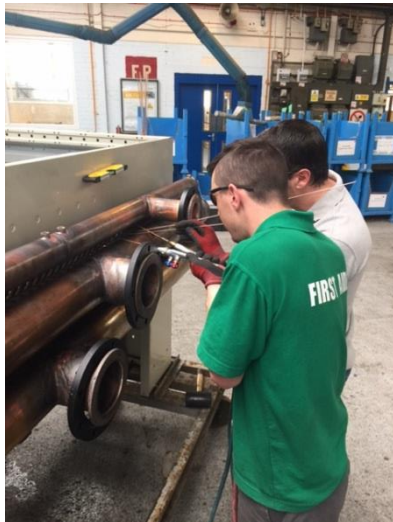

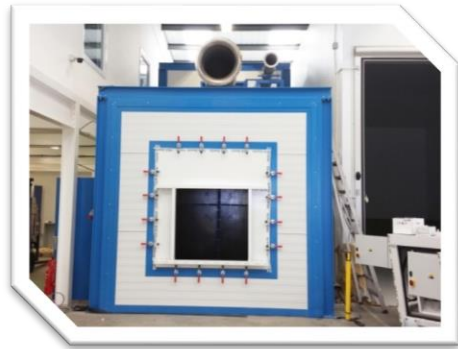

- Air flow test rig
- Inner calorimeter room
- Environmental test
- A hot-water
- R507 refrigeration pack
- Transcritical CO2 refrigeration
- The new X-ray microtomography



- Availability of specialists in different fields of research
- Academics at the forefront of research
- Availability of a wide variety of test equipment
- Access to alternative sources of funding
- Improved reputation with our customers

Why We Chose **CSEF**-Brunel?



- Strong reputation for ground breaking research
- Experience in the field of investigation
- A relationship with many of our customers
- This is not Searle's first project with Brunel

Using carbon dioxide as a refrigerant is not a new idea but, with the increasing concern about global warming, natural refrigerants have made a comeback.

- Driven by regulation limiting the availability of conventional refrigerants.
- Supermarkets, looking at long term plans for refrigeration needed an alternative.
- Carbon Dioxide best meets the requirements.
- Changes in heat exchange technology are required.



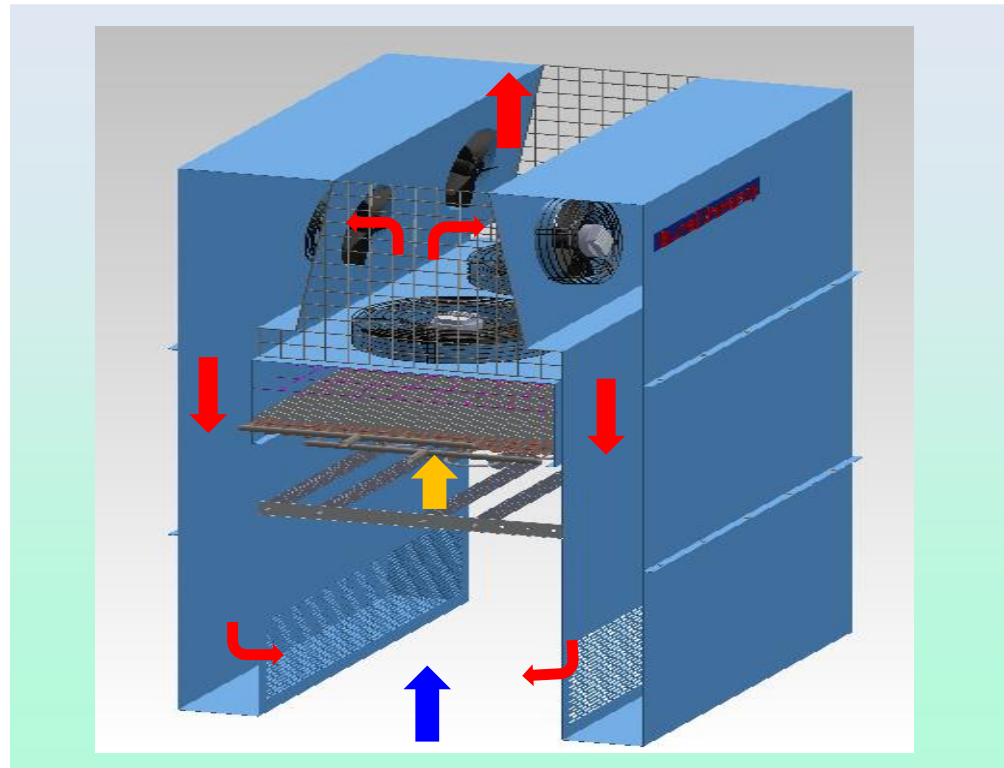

- Recirculation fans for controlling inlet temperature.
- Interchangeable coil for testing alternative geometries.

- Improved thermal capacity of the working fluid and higher working pressure makes 8mm the optimised tube diameters for this application
- Extensive CFD analysis was used to define / optimise coil geometries and so reduce unit energy consumption.

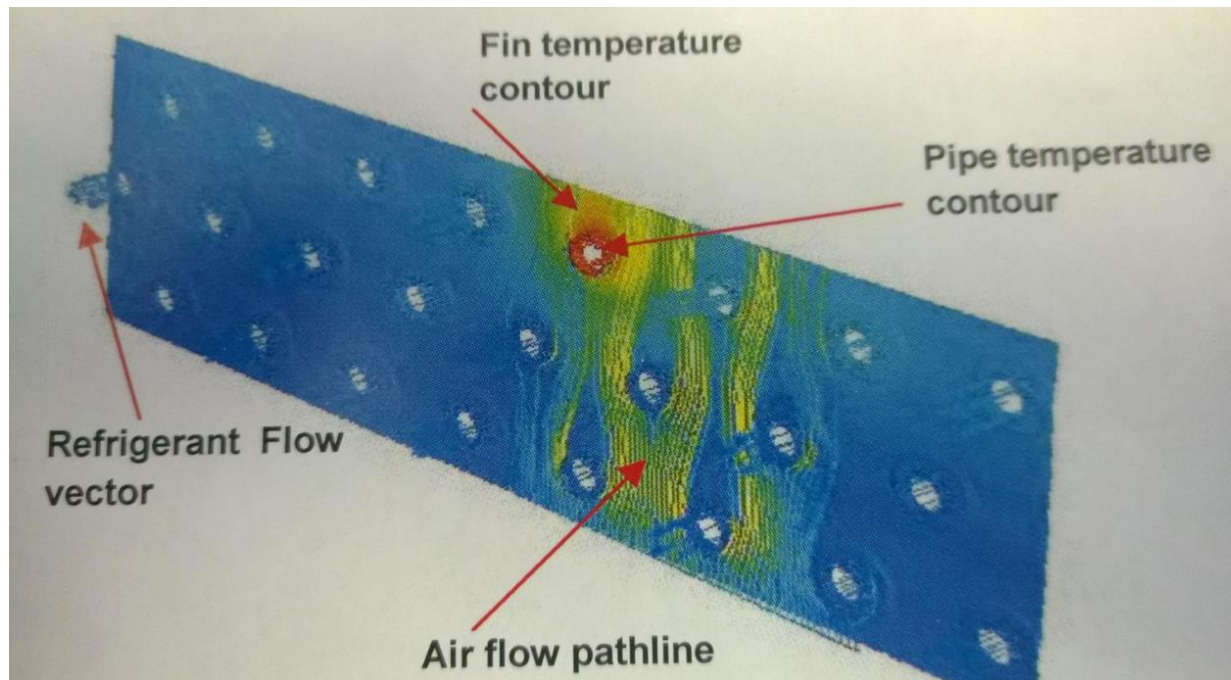

Original coil geometry

Heat from the high temperature inlet tubes spreads to adjacent tubes and reduces the overall heat transfer.

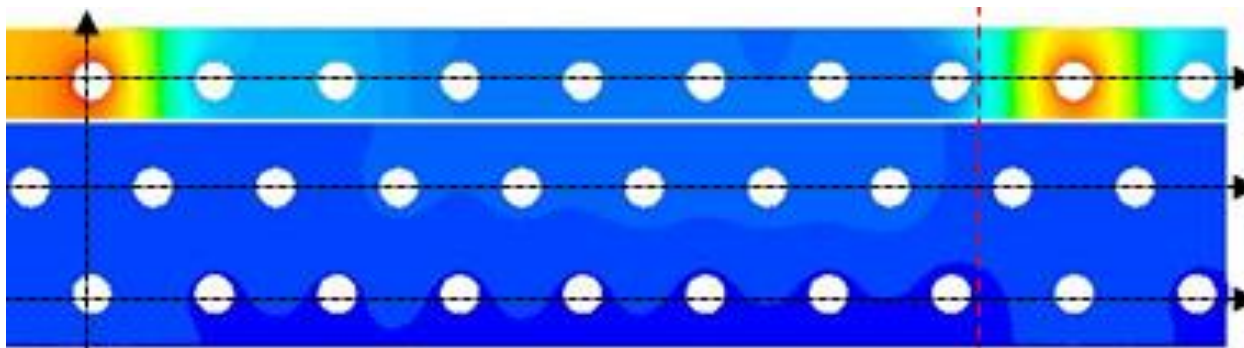
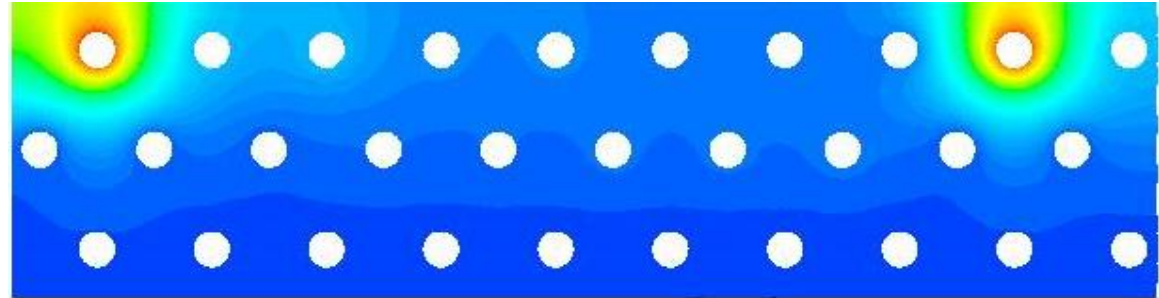

With a horizontal split in the coil block – overall heat transfer increase of approximately 7%

Any increase in heat exchanger performance enables a reduction in energy requirement for a specific performance.

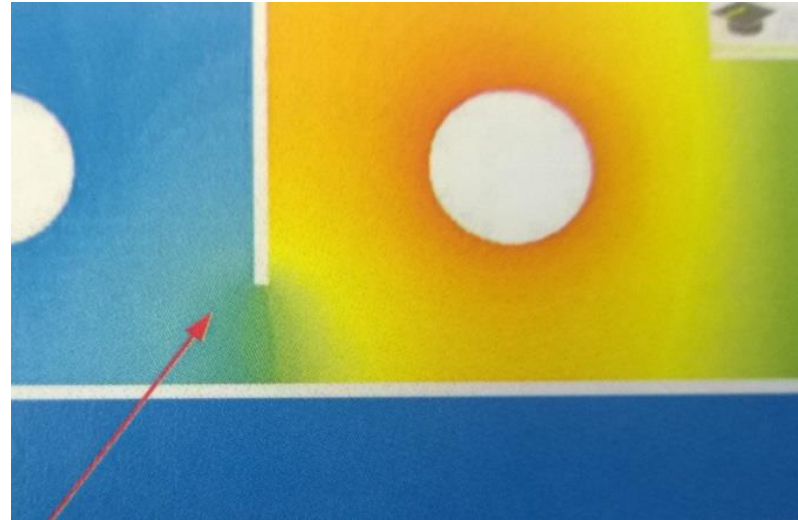
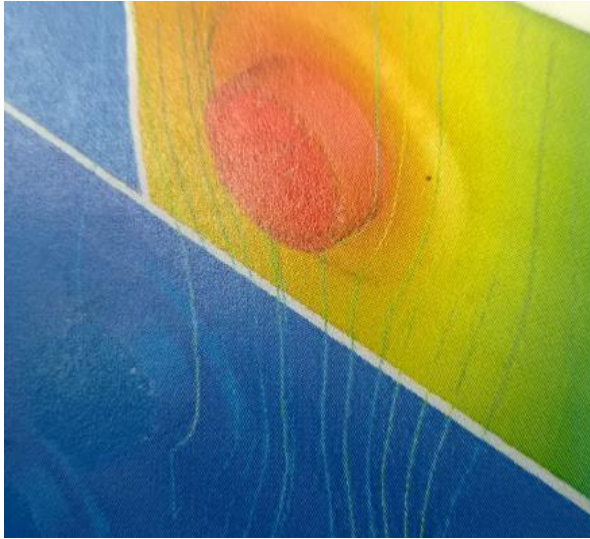

Addition of a vertical slit can offer a further 2% performance increase.

Implementation of selected features from above helped Searle to massively increase market share for CO₂.

- Using carbon dioxide as the working fluid in a Rankine cycle.
- Uses waste heat at 200-350°C to evaporate the refrigerant.
- The gas drives a turbine to generate electricity.
- The reduced pressure gas is then condensed.
- The fluid is then pumped to high pressure for evaporation.
- Using carbon dioxide as the working fluid improves efficiency.

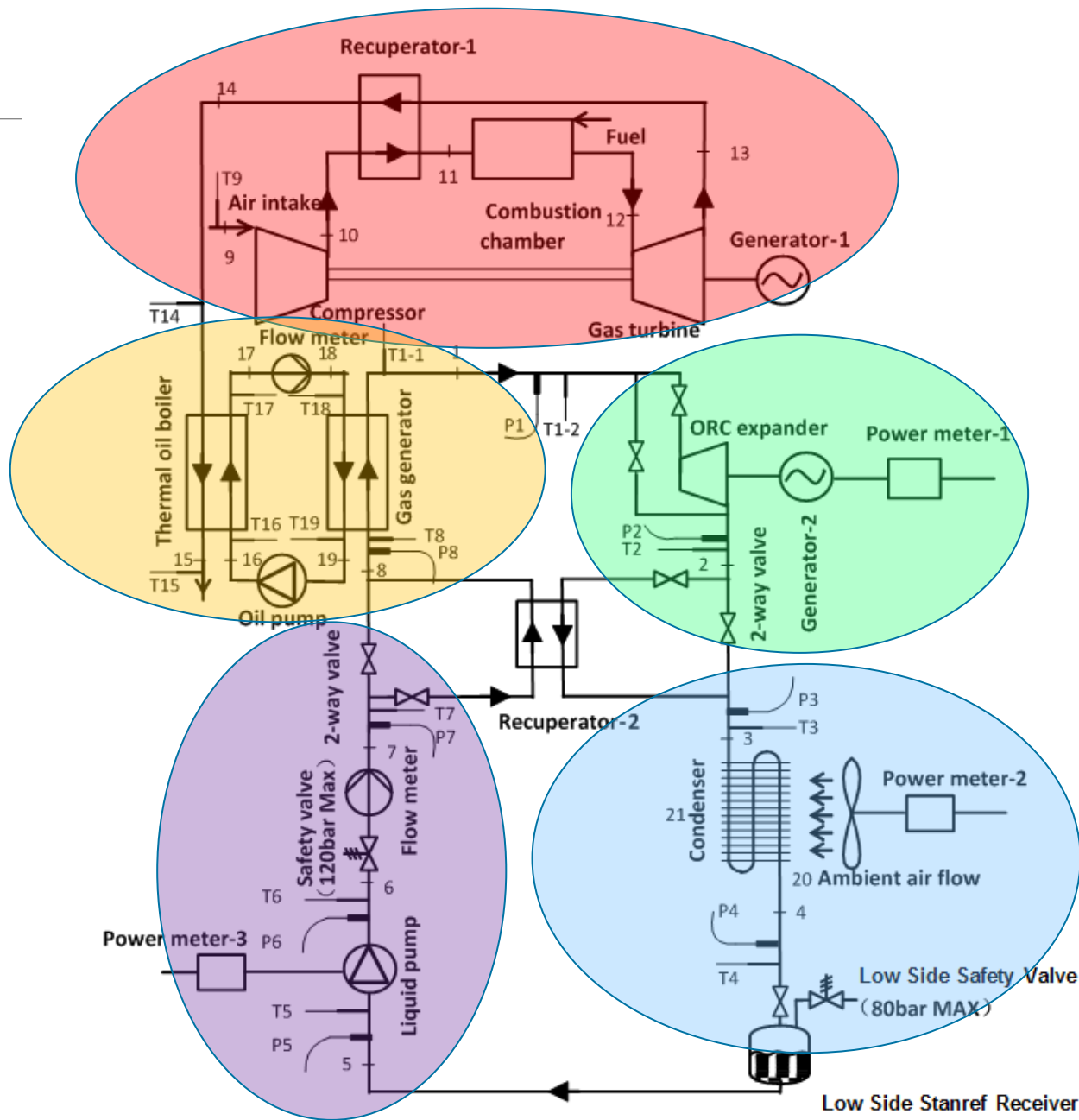

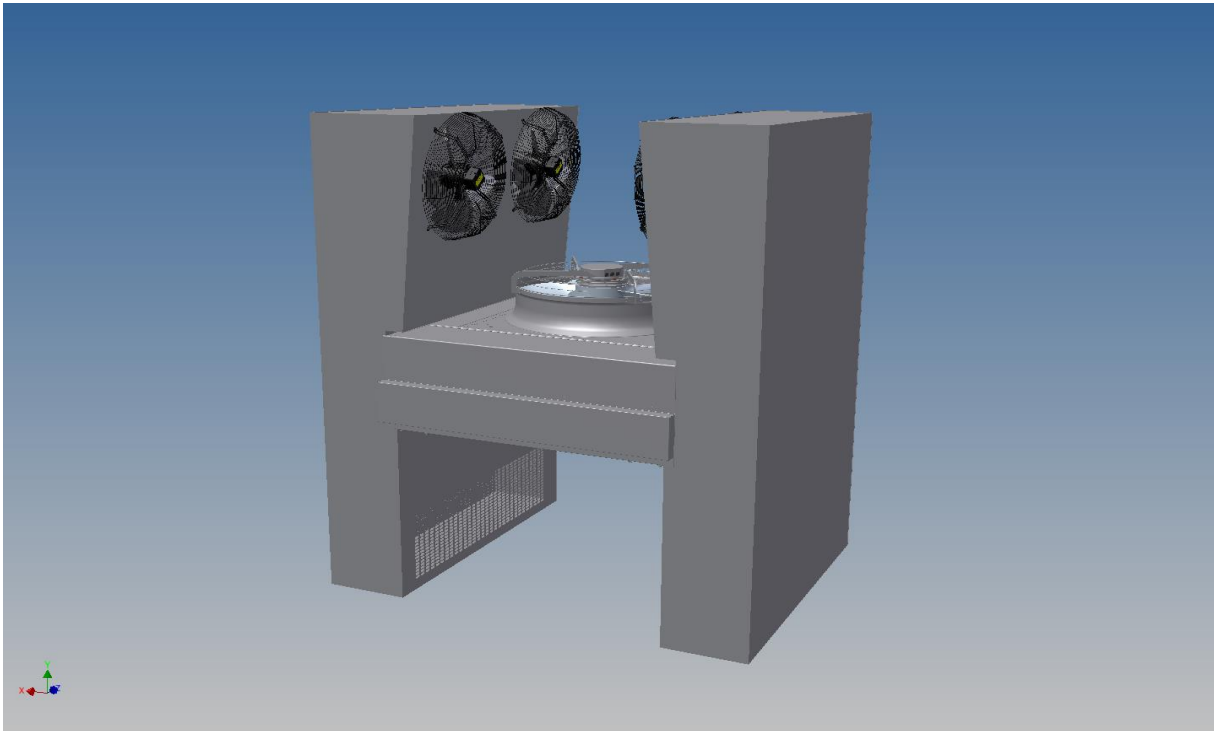

- Recirculation fans for controlling inlet temperature.
- Adiabatic cooling system included to maintain liquid to pump at high ambient.
- Combined with R245fa coil for parallel project.

- CSEF-Brunel dealt with the majority of the application process.
- Innovate UK appoint a monitoring officer who is responsible for overseeing the progress and finances of the project.
- Quarterly meetings are held.
- The process of claiming funding is straightforward.
- Project extension was granted when difficulties in obtaining test rig components caused delays.
- The project officer provides guidance and support in all dealings with Innovate UK.

Project Deliverables

- Completion of test program.
- Validation of mathematical model.
- Optimisation of rig design and control for maximum efficiency.

Following the success of the projects above, further ORC projects are under consideration with RCUK Center for sustainable Energy use in the food chain.

Thank you for your attention.

Heat exchange with HX-Factor
energizes the world.

